



DATA SHEET



Model: LCDF 460 W MINI

Laboratory Chest Deep Freezer

Description

Color: White
Panel: MINI
LED backlit control panel
Audible and visual alarms

TECHNICAL FEATURES

Product Code BBE600
Temperature -20°C / -45°C
Refrigeration Type Static
Defrost Type Manual
Refrigerant Gas R290
Climatic Class $+16^{\circ}\text{C}$ / $+38^{\circ}\text{C}$ (ST)
Gross Capacity (liters) 480
Net Capacity (liters) 460
External Dimensions :
(W x D x H mm) 1710 (MINI) / 1990 (ADV) x 730 x 870

ELECTRICAL DATA

Power Supply (V/ph/Hz) 220-230/1/50
Energy Consumption (kWh/24h) 2,0

STRUCTURAL FEATURES

Structure Chest
Insulation Thickness (mm) 100
Counterbalanced Lid Yes
Heated Door Seal Yes
Maximum Shelf Quantity -

CONTROL PANEL

Display Type LED
Probe Type Nr. 1 NTC
Alarm Signaling Acoustic and visual
Alarm Indications Codes
Adjustable High/Low Temperature Alarm Yes
Probe Fault Alarm Yes
Calibration Yes

ACCESSORIES

Basket
One-way rollers \varnothing 20 mm
Temperature chart recorder
GSM/GPRS telephone dialer (available for ADVANCED control panel only)
Voltage 230V/1ph/60Hz
Plug type G
Plug type I
Wooden crate packing
IQ Documentation
OQ Documentation

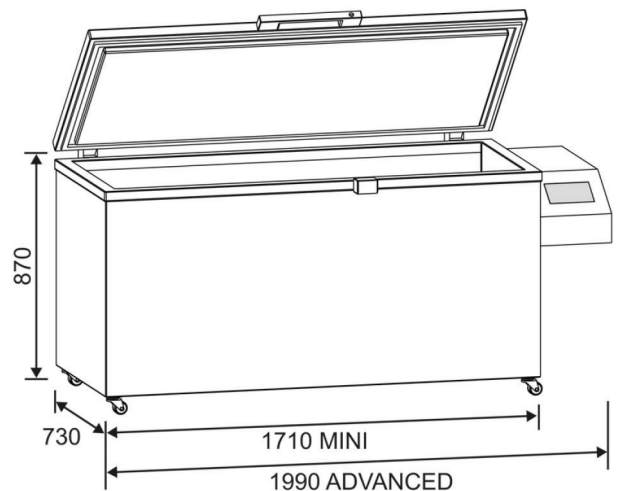

ESSE3 srl, Via Garibaldi 30
14022 Castelnuovo D.B. (AT)
Tel +39 011 99 27 706
Fax +39 011 99 27 506
e-mail esse3@chierinet.it
web: www.esse3.dreamgest.com

